



Thermopile Temperature Sensor (Model: MRT311)

User's Manual

Version: 1.0

Valid from: 2019-11-18

Zhengzhou Winsen Electronics Technology Co., Ltd

Statement

This manual copyright belongs to Zhengzhou Winsen Electronics Technology Co., LTD. Without the written permission, any part of this manual shall not be copied, translated, stored in database or retrieval system, also can't spread through electronic, copying, record ways.

Thanks for purchasing our product. In order to let customers use it better and reduce the faults caused by misuse, please read the manual carefully and operate it correctly in accordance with the instructions. If users disobey the terms or remove, disassemble, change the components inside of the sensor, we shall not be responsible for the loss.

The specific such as color, appearance, sizes &etc, please in kind prevail.

We are devoting ourselves to products development and technical innovation, so we reserve the right to improve the products without notice. Please confirm it is the valid version before using this manual. At the same time, users' comments on optimized using way are welcome.

Please keep the manual properly, in order to get help if you have questions during the usage in the future.

Zhengzhou Winsen Electronics Technology CO., LTD.

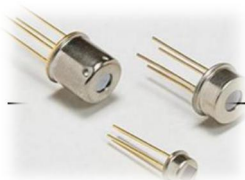

MRT311 Thermopile Temperature Sensor

TO-46 Package

MRT-311 thermopile sensor is based on MEMS technology, consists of hundreds of thermocouples connected in series. Using Seebeck principle, when there is a temperature difference between the target and the environment, the sensor gives the corresponding voltage output, therefore detecting the existence of the target or the temperature of the target.

Features

- TO-46 metal package
- High sensitivity
- Quick response, Good stability
- High filter transmittance
- High precision NTC

Applications

- Non-contact temperature measuring
- Infrared thermometer, such as ear temperature and forehead temperature measurement
- Continuous temperature control of production process
- Household appliances (Microwave oven, hair dryers, air conditioners etc), intelligent temperature induction and control system
- Human presence detection

Table 2 MRT311 thermopile parameters

Parameter	Value	Unit	Remarks
Chip size	1.1×1.1	mm	
Sensitive area	0.35×0.35	mm	
Field of view	95	Degree	Above 50%
Thermopile resistor	90±30	KΩ	25℃
Noise voltage	38	nV/Hz ^{1/2}	25℃
Noise equivalent power	0.23	nW/Hz ^{1/2}	500K, 1Hz, 25℃
Response rate	160±40	V/W	500K, 1Hz, 25℃
Temperature coefficient of resistance	0.06	%/℃	25℃~75℃
Time constant	≤13	ms	
Detection rate	1.5 ×10 ⁸	cmHz ^{1/2} /W	500K, 1Hz, 25℃
NTC resistance	100 ± 1%	KΩ	25℃
NTC(β)	3950 ± 1%	/	25℃/50℃
Working temperature	-30 ~ 100℃		
Storage temperature	-40 ~ 110℃		

Sensor diagram(unit:mm)

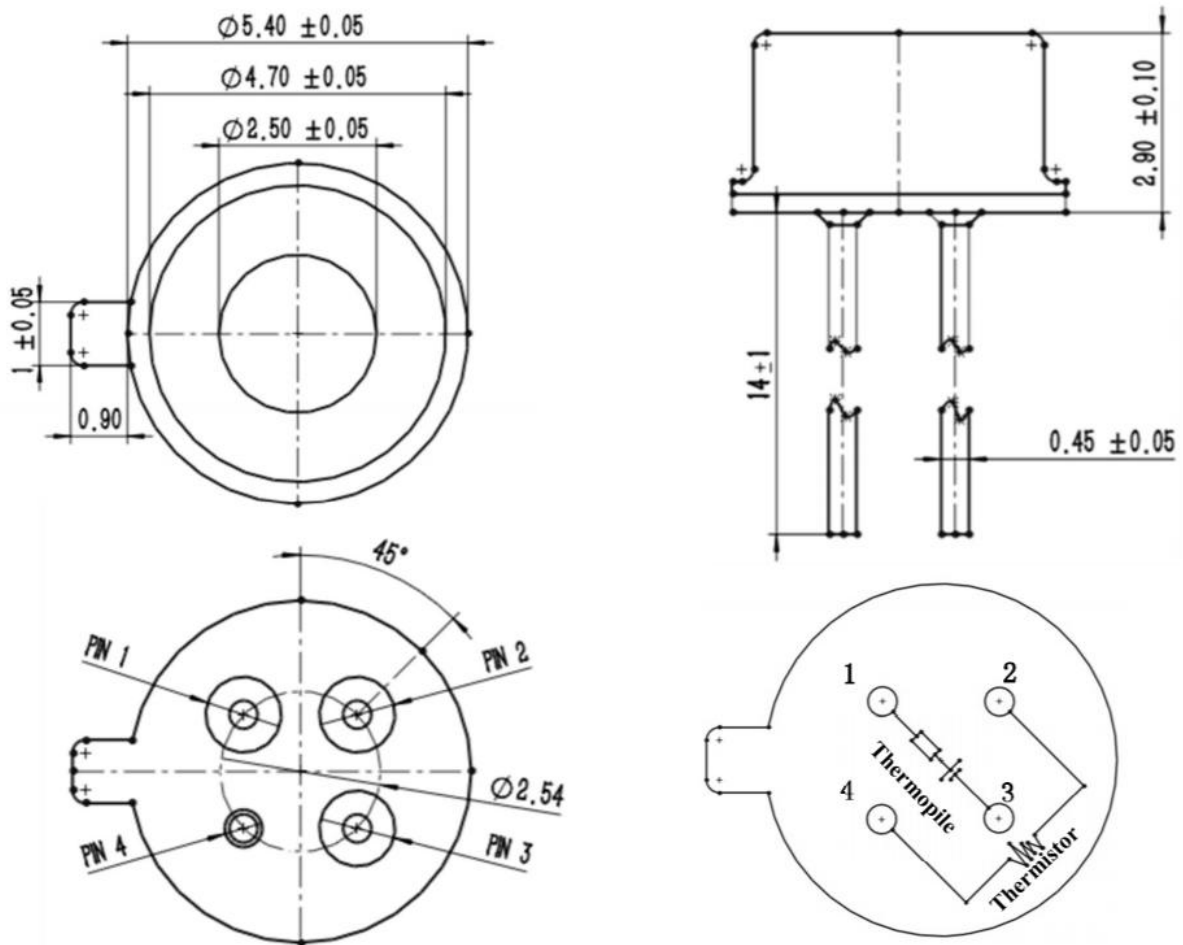

Electrode connection:

Pin	1	2	3	4
Definition	Thermopile positive	NTC	Thermopile negative	GND

1. Typical thermopile performance (V-T) curve:

Testing condition: 25°C, TO-46 package, LWP5.5 filter

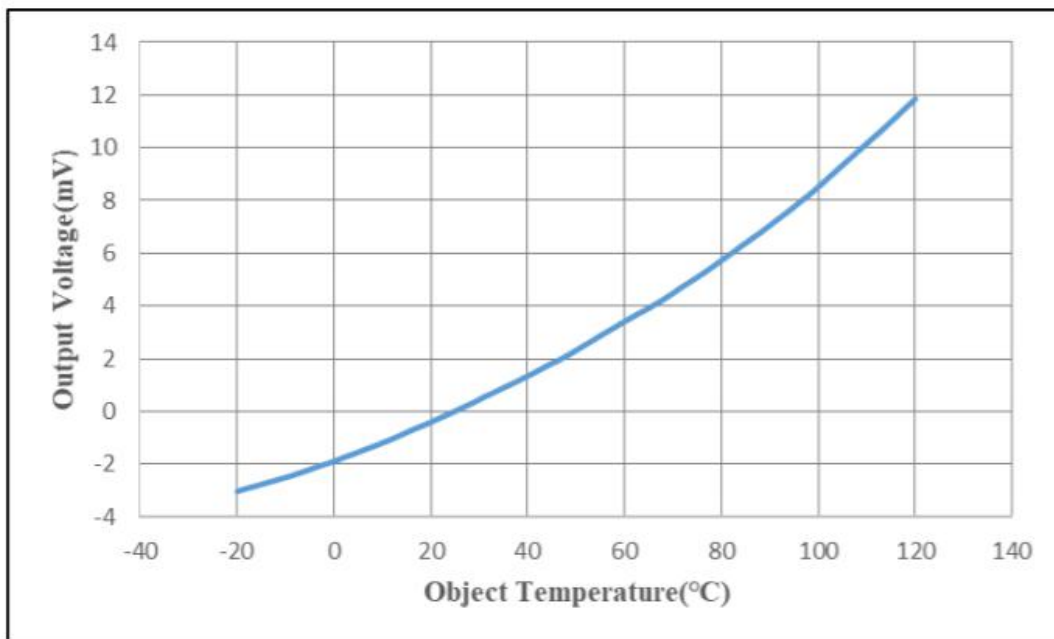

2. Filter Performance Curve

Parameter	Value	Unit	Remarks
Wavelength range	5.5~14	um	
Transmittance 1	≥75	%	Average, 5.5~14um
Transmittance 2	<1	%	<5μm

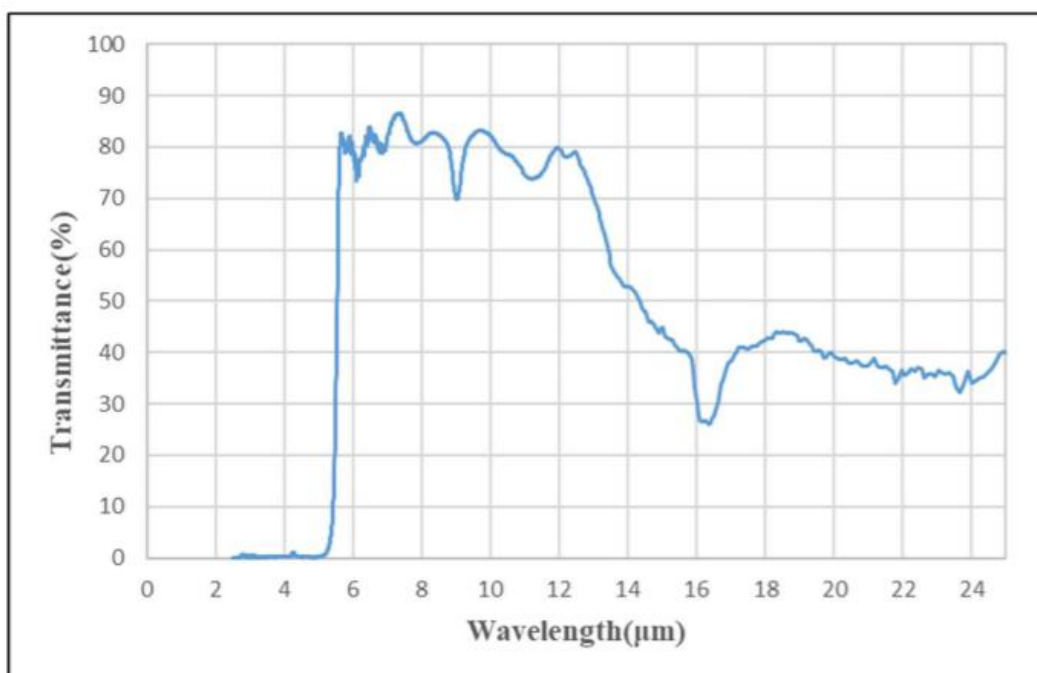

3. Thermistor (NTC) R-T Table

T(°C)	R(KΩ)	T(°C)	R(KΩ)	T(°C)	R(KΩ)	T(°C)	R(KΩ)
-30	1787.9797	3	280.9084	36	62.5954	69	17.9562
-29	1679.6017	4	267.2014	37	60.0707	70	17.3452
-28	1578.5061	5	254.2428	38	57.6610	71	16.7578
-27	1484.1584	6	241.9877	39	55.3604	72	16.1930
-26	1396.0662	7	230.3940	40	53.1635	73	15.6499
-25	1313.7754	8	219.4224	41	51.0651	74	15.1276
-24	1236.8685	9	209.0361	42	49.0602	75	14.6251
-23	1164.9598	10	199.2007	43	47.1443	76	14.1417
-22	1097.6941	11	189.8841	44	45.3130	77	13.6764
-21	1034.7432	12	181.0559	45	43.5621	78	13.2286
-20	975.8038	13	172.6881	46	41.8878	79	12.7976
-19	920.5962	14	164.7540	47	40.2862	80	12.3825
-18	868.8615	15	157.2290	48	38.7539	81	11.9828
-17	820.3603	16	150.0898	49	37.2876	82	11.5978
-16	774.8710	17	143.3144	50	35.8842	83	11.2270
-15	732.1889	18	136.8825	51	34.5405	84	10.8697
-14	692.1238	19	130.7749	52	33.2538	85	10.5254
-13	654.4999	20	124.9734	53	32.0214	86	10.1935
-12	619.1540	21	119.4612	54	30.8408	87	9.8736
-11	585.9346	22	114.2223	55	29.7096	88	9.5652
-10	554.7016	23	109.2417	56	28.6253	89	9.2678
-9	525.3245	24	104.5053	57	27.5860	90	8.9809
-8	497.6821	25	100.0000	58	26.5895	91	8.7042
-7	471.6621	26	95.7132	59	25.6338	92	8.4373
-6	447.1599	27	91.6333	60	24.7171	93	8.1797
-5	424.0781	28	87.7492	61	23.8376	94	7.9312
-4	402.3264	29	84.0505	62	22.9937	95	7.6912
-3	381.8204	30	80.5274	63	22.1836	96	7.4596
-2	362.4818	31	77.1707	64	21.4061	97	7.2360
-1	344.2375	32	73.9717	65	20.6594	98	7.0201
0	327.0195	33	70.9222	66	19.9424	99	6.8115
1	310.7640	34	68.0144	67	19.2537	100	6.6101
2	295.4121	35	65.2411	68	18.5920	101	6.4155

Temperature measurement step

- (1) Read the resistance value R_a between pin 2 and 4;
- (2) Find the ambient temperature T_a according to R_a 's last R-T table in the specification;
- (3) reading the voltage V_a between pin 1 and 3;
- (4) Find the voltage value equal to or close to the V_a value in the T_a column of the V-T table, and the corresponding abscissa is the temperature of the measured object.

Note:

The sensor must first calibrate the resistance of the thermistor NTC;

The sensor test is affected by factors such as black body temperature, distance, and environment. The V-T table is for reference only. The V-T meter needs to be calibrated before use.

The output voltage of the sensor is easily affected by the NTC resistance value. It is necessary to increase the thermal resistance and heat capacity to increase the temperature stability. Generally, metal (copper, aluminum) kits are used;

In order to reduce the thermal interference between the sensor pins, the sensor pins should be thermally isolated when making a PCB.

Frequent, excessive vibration, strong impact or collision will cause resonance inside the sensor to break.

Zhengzhou Winsen Electronics Technology Co., Ltd

Add: No.299, Jinsuo Road, National Hi-Tech Zone,
Zhengzhou 450001 China

Tel: +86-371-67169097/67169670

Fax: +86-371-60932988

E-mail: sales@winsensor.com

Website: www.winsen-sensor.com

REALTOP International Co.,Ltd.

주소.: 서울시 강서구 공항대로 200,
마곡 지웰타워 1108호(우편번호 07631)
연락처.: 02-2064-0080
이메일.: jeff@realtopint.com
웹사이트.: <https://www.realtopint.com/>